



FICHE PRODUIT - PRODUCT SHEET

997N



No. Ref.: 3016200997146

CASE IH 580 Super N WITH SWIVEL SEAT +LOADER+DIGGER  
CASE IH 580 Super N WITH SWIVEL SEAT +LOADER+DIGGER

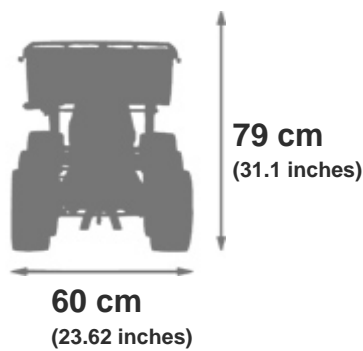
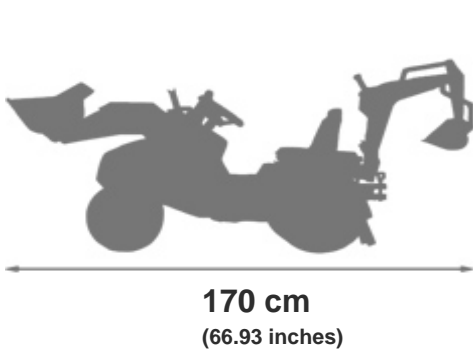

Colis/Parcel

361 dm<sup>3</sup>  
(12.73 ft<sup>3</sup>)

111 x 58 x 56 cm  
(43.7 x 22.83 x 22.05 inches)

Packing unit 1



**3/7**  
YEARS

Children max weight: 50 kg  
(110 lbs)



FALQUET & CIE 22 Rue Jean Mermoz - 01100 OYONNAX - FRANCE

Tel : +33 (04) 74 77 50 46 - Fax: +33 (04) 74 77 60 61 [contact@falquet.fr](mailto:contact@falquet.fr) - [www.falk-toys.com](http://www.falk-toys.com)